

GK3 / GK4 - Ground Position Light Signal kit - Yellow and White

CAUTION - ALWAYS SWITCH OFF POWER TO YOUR LAYOUT BEFORE CONNECTING OR DISCONNECTING ANY ACCESSORIES

This signal kit contains a Ground Position Light Signal kit designed for use on OO/HO gauge model railways - please read these instructions before assembly and connecting to power. (note that GK3 and GK4 are now identical products)

1 Introduction

Contents

- 1 Signal LED lights printed circuit board 'PCB'
- 1 Ground Position signal front and back cover
- 1 Mounting cap (two halves)
- 2 1KΩ resistor (Colour: Black Brown Red Gold)
- 1 Instruction leaflet

Recommended tools (not included)

- Plastic Adhesive
- Craft knife (for trimming 'flash' off mouldings)
- Soldering iron and solder for connections

Thank you for purchasing one of our Ground Position Light Signal (GPLS) kits. This is a White and Yellow light version - note GK3 and GK4 are now identical kits as we have combined both light combinations into the same signal head. There is also a White and Red light version GK1/GK2.

Below we have given a basic introduction to the use of Ground Position signals but more details can be found in signalling books and online.

In this kit we have utilised the latest LEDs for the lights but unlike most signal kits we have presoldered them onto narrow printed circuit boards which makes them easy to connect. You can either control this signal using conventional Lever frame or Toggle type switches or connect it to a DCC decoder to control it from a Digital controller or computer. Note that Train-Tech also offers another version of this signal (GS1/GS2) which has electronics built in with inputs for a Train-Tech track sensor to allow the signal to change automatically (powered from DC or DCC) and a decoder so that you can control it from a DCC controller.

Take extra care when using tools and adhesives.

2 Assembling and mounting the signal

The exploded diagram below shows you the components which make up the signal. It is easy to assemble, with just the front and back covers needing to be fixed together over the head. Firstly, check and trim the mouldings for any 'flash'. There are tiny LED lights mounted on the signal head circuit board which you must not damage. **We strongly recommend** that you apply a tiny amount of plastic kit glue to the edge of the back cover **first**, lay it on a flat surface, then fit the signal light head into the rear cover (so that no glue gets near the LED lights). Finally align the front cover onto the rear cover & hold in position until glue set.

Apply a *small* amount of glue around edge of rear cover, then fit light head inside

Care - tiny LEDs!

Fit front cover over the signal head and hold until glue is set

Two-part mounting cap which can be used to mount the signal securely in a 10mm hole in your baseboard - no need to glue together. Note it allows the head to be held at 2 different heights to give space for location board etc

Connection Terminals for lights (see right)

3 Connecting the signal

The LED lights are presoldered onto a PCB which has large contacts at the bottom to connect your wires to. You can control it using a conventional switch or a DCC decoder (eg Train-Tech SC1). We have wired the 4 LED lights to separate terminals so you can wire them as you wish, either as the original single yellow / dual white or current double yellow / dual white configurations as below. **You MUST fit resistors as shown below or you will cause permanent damage to the signal LEDs** (Note Train-Tech DCC SC1 have resistors inside)

Double yellow or double white

Common - Yellow
Right Yellow +
Left Yellow +
Top White +
Right White +

2 way switch
9-16 volts DC
- Negative
+ Positive
1kΩ resistor

White + single yellow/single white

Common - Yellow
Right Yellow +
Left Yellow +
Top White +
Right White +

2 way switch
9-16 volts DC
- Negative
+ Positive
1kΩ resistors

Ground Position Light Signals & mounting

Position light signals which display yellow aspects are stop signals which apply only to movements in the direction to which the signal can be cleared and are commonly located around the exits of marshalling yards and sidings. They are always lit and two diagonal white lights lit means that the driver can proceed with caution at a speed they are able to safely stop if needed:



Proceed with caution

Two horizontal yellow lights or a yellow & white light means stop, but the driver may pass when a movement is being made towards the shunt neck or siding and not the running line:

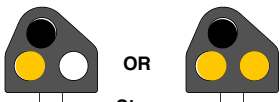

Stop

There are two different light configurations and both are valid. The yellow plus white light version represents the original GPLS, where only one coloured light is fitted behind a lens, whereas the current style has two yellow lights but the bottom right light has the ability to display yellow or white. Full details shown in signalling books or online.

This kit is designed so that you can wire your signal to show either style. If you decide to show the original style then wire the bottom right white LED to be lit all of the time using the extra resistor supplied, and switch between the top white and bottom left red LED.

Other ground position signals with white & red lights are also available from Train-Tech.

Mounting the signal on your baseboard

You can drill a 10mm hole in your baseboard to accept the mounting cap, or alternatively you can make a smaller hole and use filler to hold in place.

Wiring advice

Electrical connection to the signal is via metal 'pads' at the bottom of the LED light PCB. These pads are made from thin copper bonded to the fibreglass and then 'tinned' to ensure reliable and easy connection. The best method of connection is by soldering wires onto these pads using a small tip soldering iron of 18-25 watts, taking care not to apply heat for too long. Note that by pre-tinning wires before soldering onto the pads you will find that the solder will flow much more easily to make a secure joint quickly. If you prefer not to solder then you can wrap thin stranded wire around the pads by stripping off insulation, twisting strands tightly together and wrapping them round the signal base and tightly binding insulation tape around each joint. However soldering is the preferred and most reliable method. Whichever method you use take care not to let the wires short circuit to each other and do not forget to fit a resistor in series as shown before powering up your new signal!

As well as Signal Controllers, Train-Tech also makes a range of other control, lighting and sound effects. Ask for brochure or see www.train-tech.com

Signal Identification Plates

Every signal on the real railway has an identification plate and the legends below can be cut out and glued onto a small piece of plastic or card and mounted just below the signal head. The mounting cap enables the signal head to be mounted in two positions and the higher position allows space for the location board. If using DCC we suggest you use the address you have programmed into your signal decoder which will make the signal easier to identify and operate.

1	2	3	4	5	6	7	8	9	10
11	12	13	14	15	16	17	18	19	20
21	22	23	24	25	26	27	28	29	30
31	32	33	34	35	36	37	38	39	40
41	42	43	44	45	46	47	48	49	50
51	52	53	54	55	56	57	58	59	60
61	62	63	64	65	66	67	68	69	70
71	72	73	74	75	76	77	78	79	80
81	82	83	84	85	86	87	88	89	90
91	92	93	94	95	96	97	98	99	100
←	DA	ES	EN	GE	GY	MY	PN	NW	
ABCDEF	GHIJKL	MNOPQR	STUVWX	YZ					
ABCDEF	GHIJKL	MNOPQR	STUVWX	YZ					

Using Signals with Train-Tech DCC controllers

Train Tech offer various LED controllers including the SC DCC signal controllers which allow signals such as this to quickly and easily connect to DCC layouts for control by Digital controller or computer. They are quick to connect needing no resistors or soldering and set up in seconds with no programming of CV codes.

Note that Train-Tech also offer Ground signals fully assembled with built in DCC decoders, GS1 & GS2

Wiring to SC1 - Double Yellow or Double White

This wiring enables DCC control between double white or double yellow lights. Follow instructions supplied with the SC1 for setting up and control.

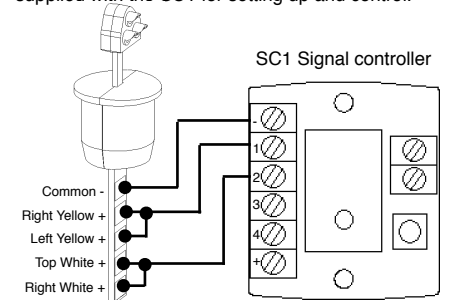

Wiring to SC1 - White & single yellow or white

This wiring is DCC control between single top white or single left yellow with a constantly lit right white. Follow instructions supplied with SC1 for setting up.

